

Data sheet KTV2-15

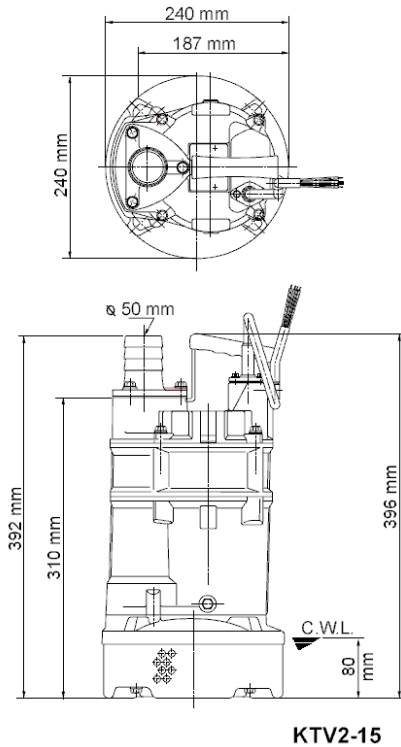

KTV2-15

CWL: Continuous running water level

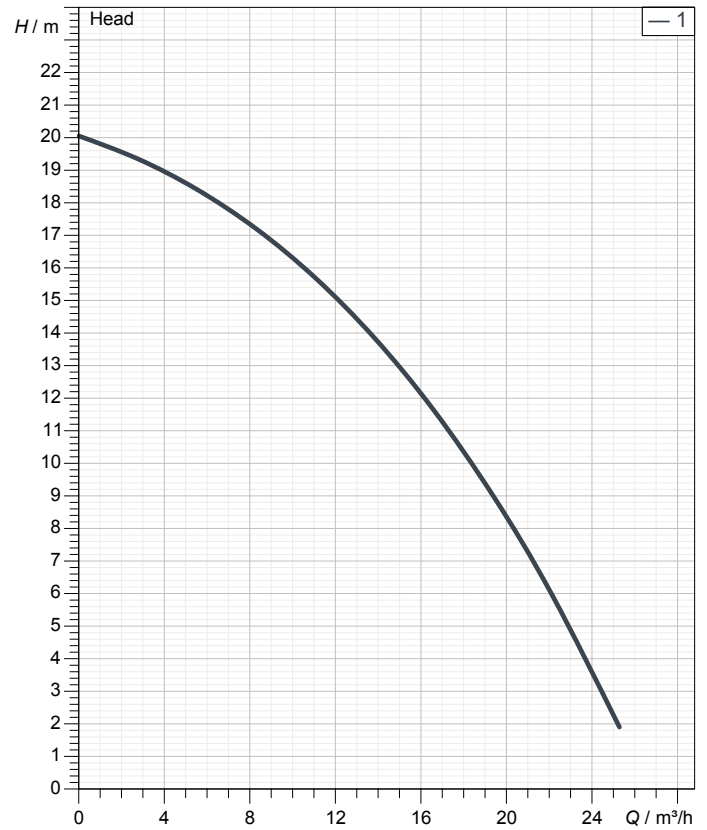

Specification

Electric submersible pump KTV-series
 Degree of protection IP 68
 Pressure resistance max. 25 m
 Type of impeller semi-vortex
 Max. solid handling 8,5 mm
 Suitable for:
 rain water, ground water, sand water

Electric motor

Dry-type submersible induction motor
 Insulation class E 2Poles 2870 1/min
 Starting mode Direct starting
 Rated voltage 400 V 50 Hz 3~
 Power uptake 2,04 kW
 Rated power 1,50 kW
 Rated current 3,3 A
 Start current 19,0 A

Cable

20m NSSHÖU 4Cx1,5mm²

Motor Protection

Circle thermal protector
 (snap-action bi-metal device)

Shaft seal

Double inside mechanical seal in oil bath
 additional lubrication by oil lifting device
 Primary seal
 Silicon carbide on silicon carbide
 Secondary seal
 Silicon carbide on silicon carbide

Bearings

Shielded ball bearings, maintenance-free

Materials

Impeller	FCD700 (EN-GJS-700-2)
Pump casing	Rubber
Motor Frame	Aluminium alloy casting
Shaft	SUS403 (EN-X6Cr13)

Discharge size

2" (50mm) Hose Coupling / BS-Coupling (optional)

Weight

21 kg (dry weight of the pump only without cable)

Performance curve

KTV2-15

Discharge port	2"
Head	20,1 m
Flow	25,3 m³/h
Rated power	1,50 kW
Power input	2,04 kW
Phases	3~
Voltages	400 V
Frequency	50 Hz
Rated current	3,3 A
Starting current	19,01 A
Number of poles	2
Speed	2870 1/min
Starting mode	Direct starting
Insulation class	E



Dimensions

KTV2-15

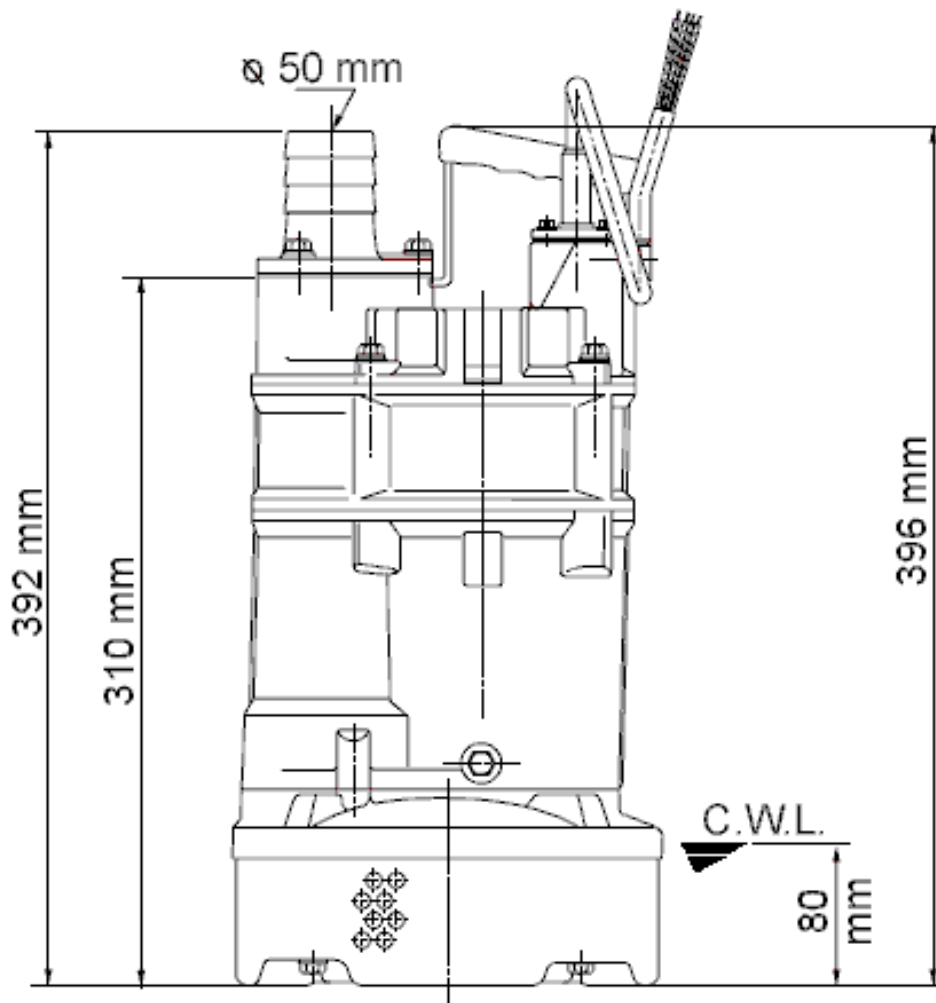
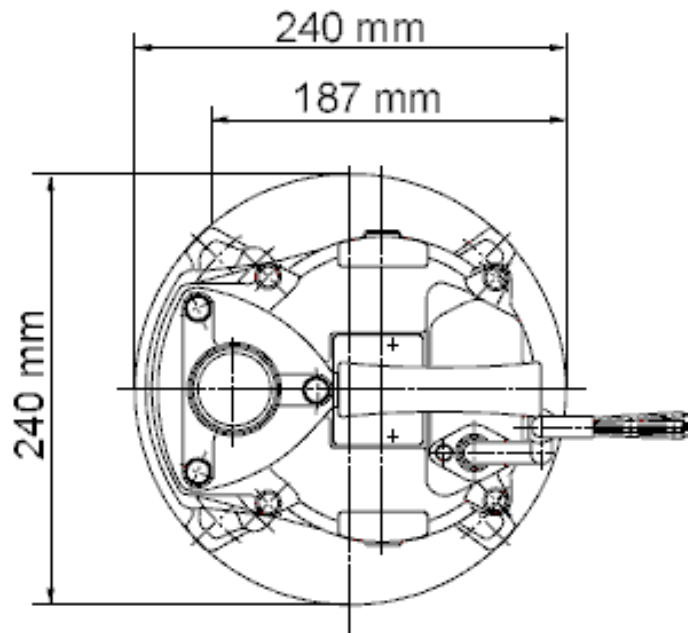

KTV2-15

CWL: Continuous running water level
LWL: Lowest running water level

Sectional drawing KTV2-15

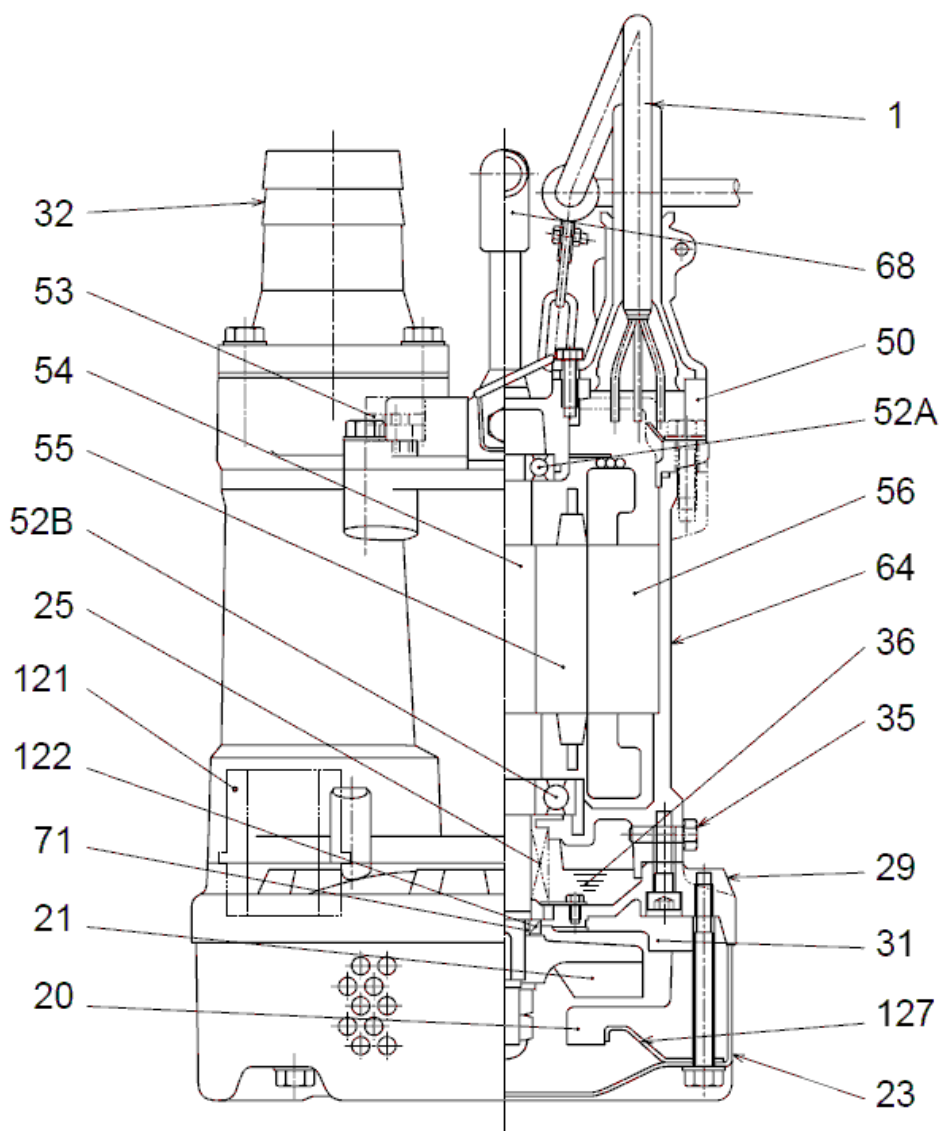

No.	Description	Remark	No.	Description	Remark
1	Cable	20m NSSHÖU	56	Stator	.
20	Pump casing	Rubber	64	Motor Frame	Aluminium alloy casting
21	Impeller	FCD700 (EN-GJS-700-2)	68	Handle	Steelplate + butadieneacrylnitrilerubber
23	Strainer	Steel plate	71	Shaft protection sleeve	SUS304 (EN-X5CrNi18-10)
25	Mechanical seal	H-20T	121	Seal	Rubber
29	Oil casing	Aluminium alloy casting	122	V-ring	Butadieneacrylnitrilerubber
31	Wear protection	Rubber	127	Pressure plate	Steel plate
32	Discharge coupling	Aluminium alloy casting			
35	Oil screw	SUS304 (EN-X5CrNi18-10)			
36	Lubricant	Turbine oil (ISO VG32)			
50	Main cover	Aluminium alloy casting			
52A	Upper bearing	6204ZZC3			
52B	Lower bearing	6305ZZC3			
53	Motor Protector 380/400/415V-50Hz	KA314-HRXL00 (H.C)			
54	Shaft	SUS403 (EN-X6Cr13)			
55	Rotor	.			