

# Data sheet KRSU822-51

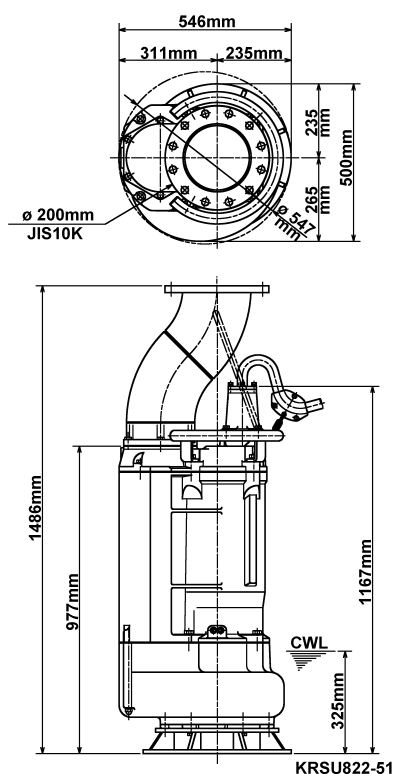

CWL: Continuous running water level



## Specification

Electric submersible pump KRSU-series  
 Degree of protection IP 68  
 Pressure resistance max. 20 m  
 Type of impeller Semi-open  
 Max. solid handling 56 mm  
 Suitable for:  
 rain water, ground water, sand water

## Electric motor

Dry-type submersible induction motor  
 Insulation class F 4Poles 1455 1/min  
 Starting mode Direct starting  
 Rated voltage 400 V 50 Hz 3~  
 Power uptake 27,09 kW  
 Rated power 22,00 kW  
 Rated current 44,6 A  
 Start current 316,2 A

## Cable

20m NSSHÖU 4Cx10mm<sup>2</sup>

## Motor Protection

Circle thermal protector  
 (snap-action bi-metal device)

## Shaft seal

Double inside mechanical seal in oil bath  
 additional lubrication by oil lifting device  
 Primary seal  
 Silicon carbide on silicon carbide  
 Secondary seal  
 Silicon carbide on silicon carbide

## Bearings

Shielded ball bearings, maintenance-free

## Materials

Impeller	FC200 (EN-GJL-200)
Pump casing	FC200 (EN-GJL-200)
Suction cover	FC200 (EN-GJL-200)
Motor Frame	FC200 (EN-GJL-200)
Shaft	SUS420J2 (EN-X30Cr13)

## Discharge size

200mm JIS10K flange

## Weight

380 kg (dry weight of the pump only without cable)

# Performance curve

## KRSU822-51

Discharge port	8"
Head	26,5 m
Flow	345,2 m <sup>3</sup> /h
Rated power	22,00 kW
Power input	27,09 kW
Phases	3~
Voltages	400 V
Frequency	50 Hz
Rated current	44,6 A
Starting current	316,21 A
Number of poles	4
Speed	1455 1/min
Starting mode	Direct starting
Insulation class	F

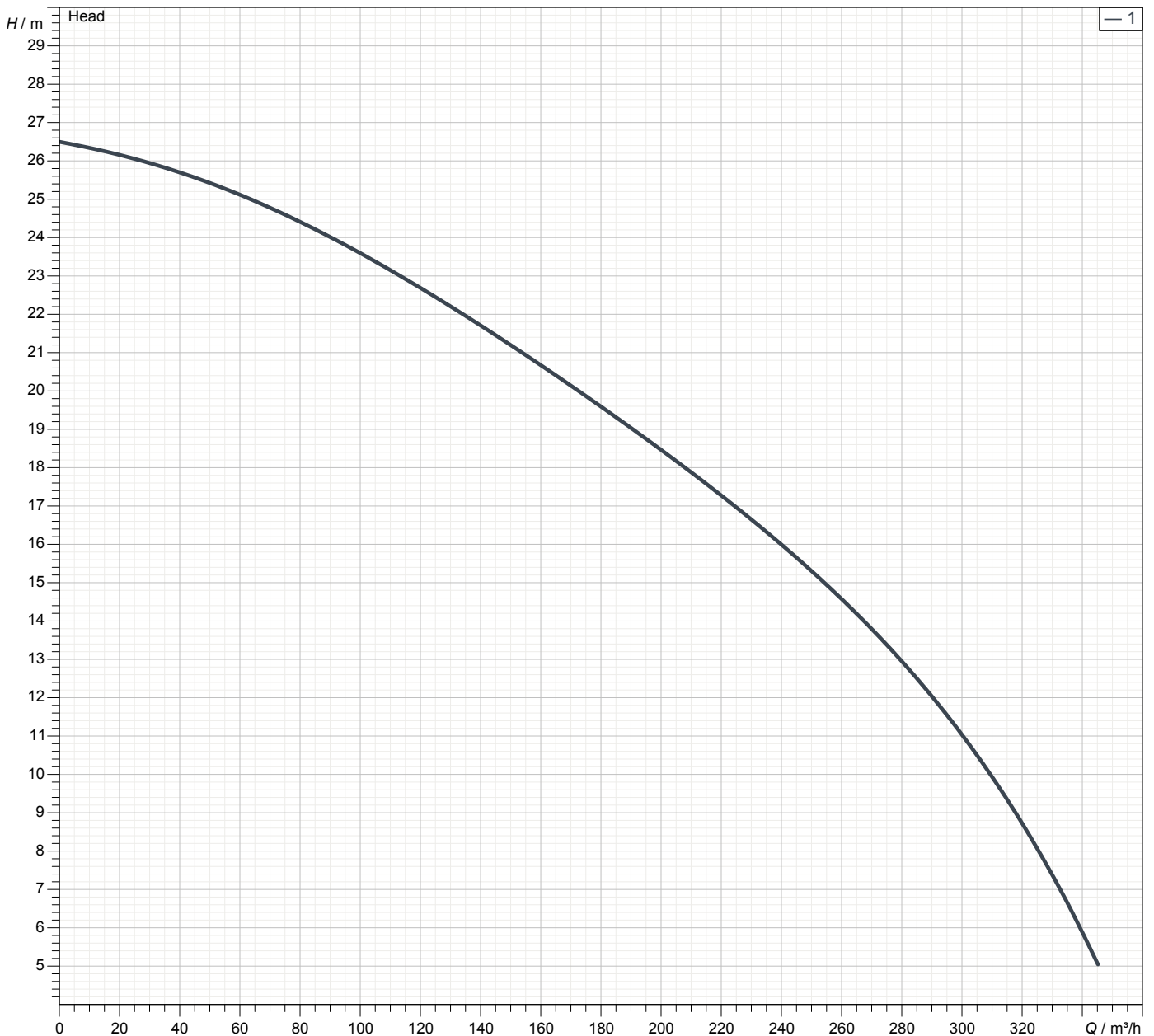

# Dimensions

## KRSU822-51

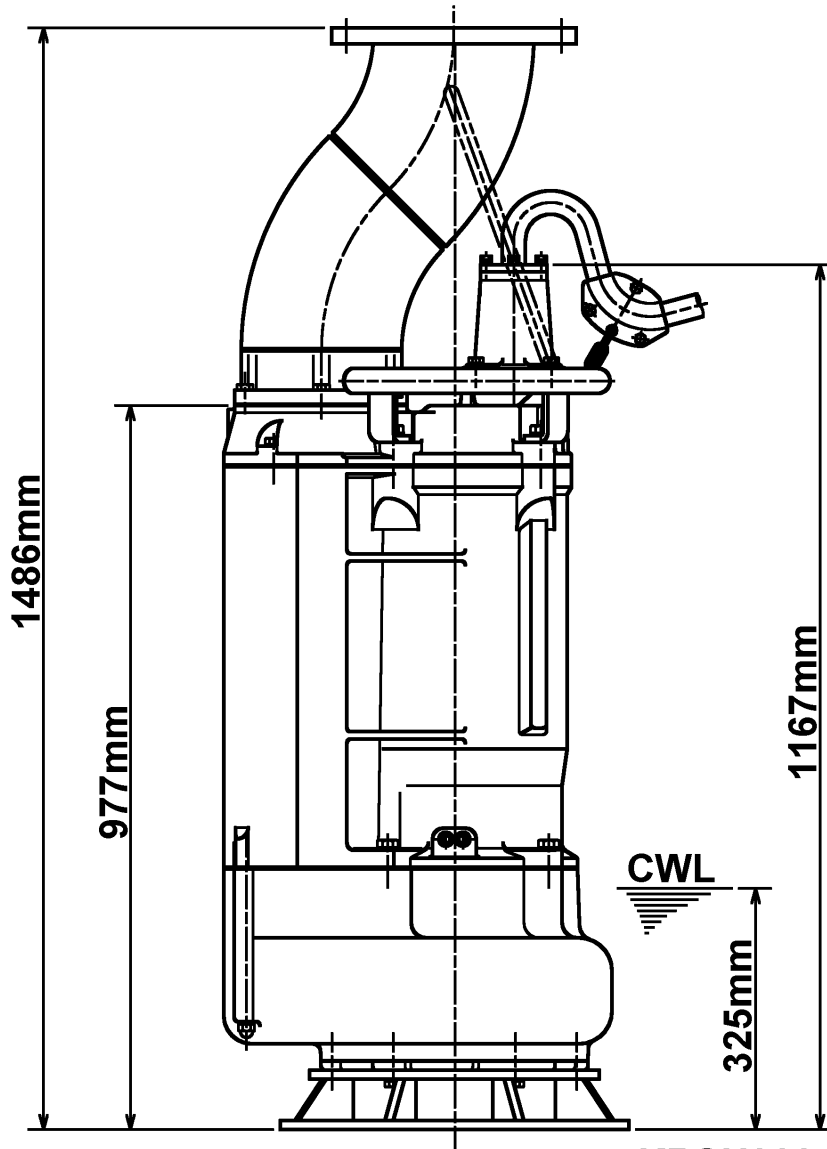
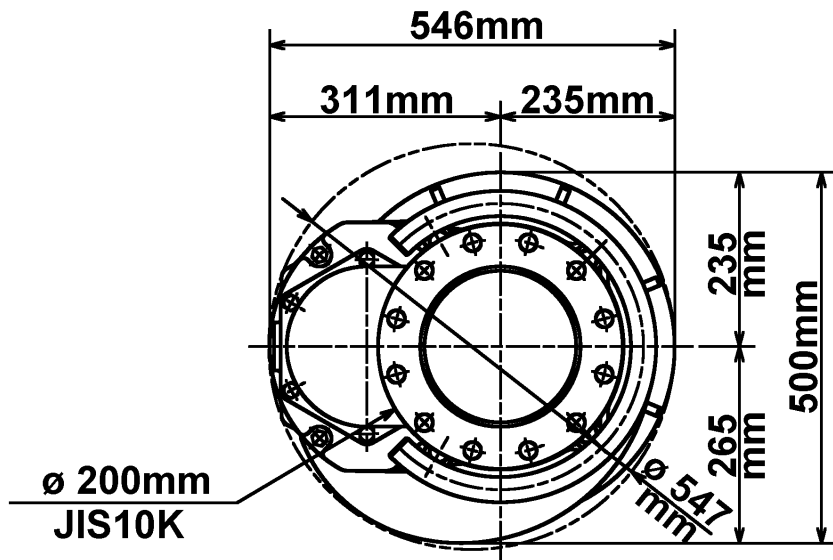

**KRSU822-51**

CWL: Continuous running water level  
 LWL: Lowest running water level

# Sectional drawing KRSU822-51

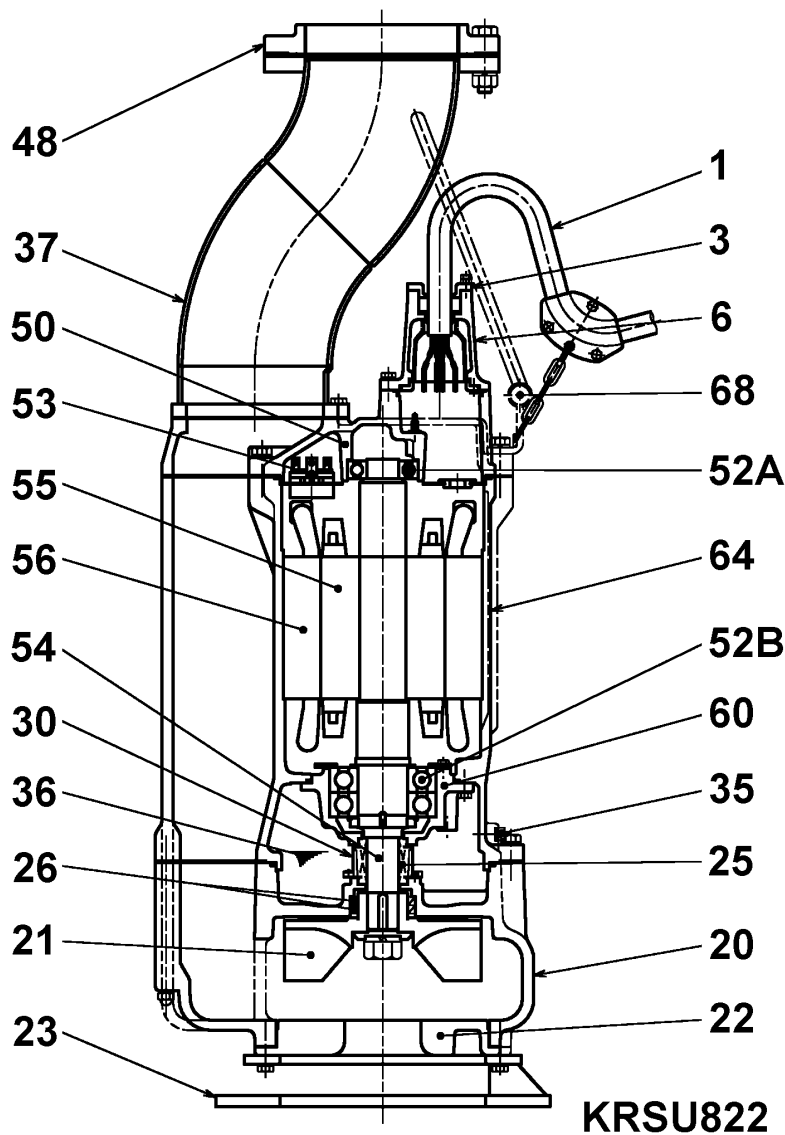

No.	Description	Remark	No.	Description	Remark
1	Cable	20m NSSHÖU	52B	Lower bearing	6314ZZC3
3	Gland	FC200 (EN-GJL-200)	53	Motor Protector 380/400/415V-50Hz	KA314-HRXL00 (H.C)
6	Stuffing box	FC200 (EN-GJL-200)	54	Shaft	SUS420J2 (EN-X30Cr13)
20	Pump casing	FC200 (EN-GJL-200)	55	Rotor	.
21	Impeller	FC200 (EN-GJL-200)	56	Stator	.
22	Suction cover	FC200 (EN-GJL-200)	60	Bearing Housing	FC200 (EN-GJL-200)
23	Strainer	Construction steel SS400	64	Motor Frame	FC200 (EN-GJL-200)
25	Mechanical seal	H-45	68	Handle	Steel plate / steel pipe
26	Oil seal	TC709212			
30	Ölverteiler	Plastic			
35	Oil screw	SUS304 (EN-X5CrNi18-10)			
36	Lubricant	Turbine oil (ISO VG32)			
37	Discharge bend	Steel plate / steel pipe			
48	Screwed Flange	FC200 (EN-GJL-200)			
50	Main cover	FC200 (EN-GJL-200)			
52A	Upper bearing	6309ZZC3			