

Data sheet LH875-51

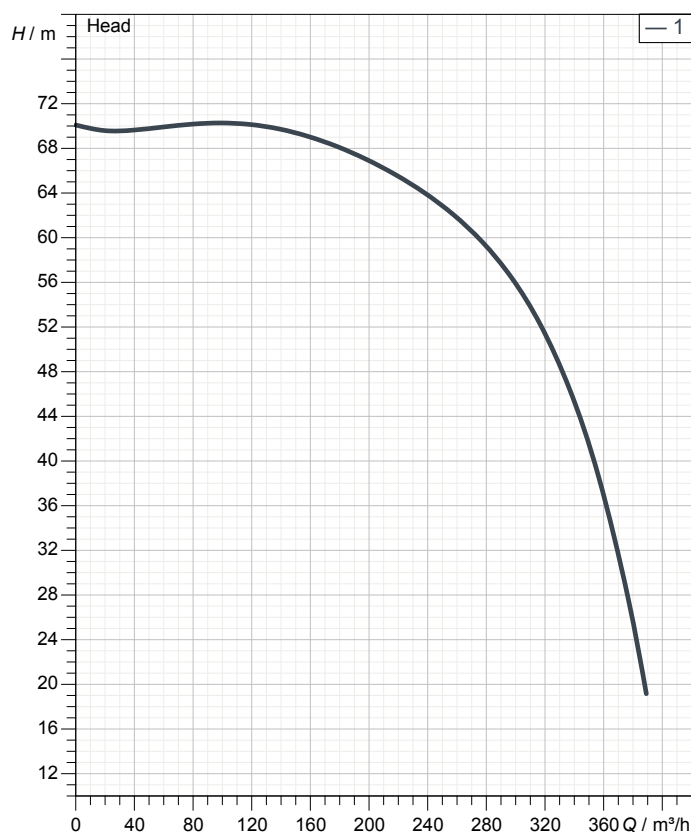
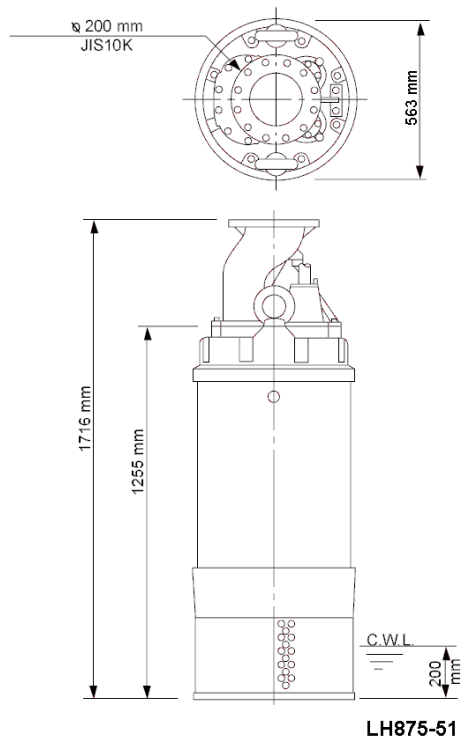

Specification

Electric submersible pump LH-series
 Degree of protection IP 68
 Pressure resistance max. 30 m
 Type of impeller Closed
 Max. solid handling 20 mm
 Suitable for:
 rain water, ground water, sand water

Electric motor

Dry-type submersible induction motor
 Insulation class F 2Poles 2940 1/min
 Starting mode Star-delta
 Rated voltage 400 V 50 Hz 3~
 Power uptake 82,42 kW
 Rated power 75,00 kW
 Rated current 130 A
 Start current 1010,1 A

Cable

20m NSSHÖU 7Cx35mm² + 3x2,5mm²ST

Motor Protection

Miniature protector in windings
 (snap-action bi-metal device)

Shaft seal

Leak sensor in oil chamber
 Double inside mechanical seal in oil bath
 additional lubrication by oil lifting device
 Primary seal
 Silicon carbide on silicon carbide
 Secondary seal
 Silicon carbide on silicon carbide

Bearings

Shielded ball bearings, maintenance-free

Materials

Impeller	Chromium iron casting
Upper Pump casing	FC200 (EN-GJL-200)
Lower Pump casing	FC200 (EN-GJL-200)
Wear Ring	Chromium iron casting
Motor Frame	FC200 (EN-GJL-200)
Shaft	SUS420J2 (EN-X30Cr13)

Discharge size

200mm JIS10K flange

Weight

865 kg (dry weight of the pump only without cable)

Performance curve

LH875-51

Discharge port	8"
Head	70,1 m
Flow	389,1 m ³ /h
Rated power	75,00 kW
Power input	82,42 kW
Phases	3~
Voltages	400 V
Frequency	50 Hz
Rated current	130 A
Starting current	336,70 A
Number of poles	2
Speed	2940 1/min
Starting mode	Star-delta
Insulation class	F

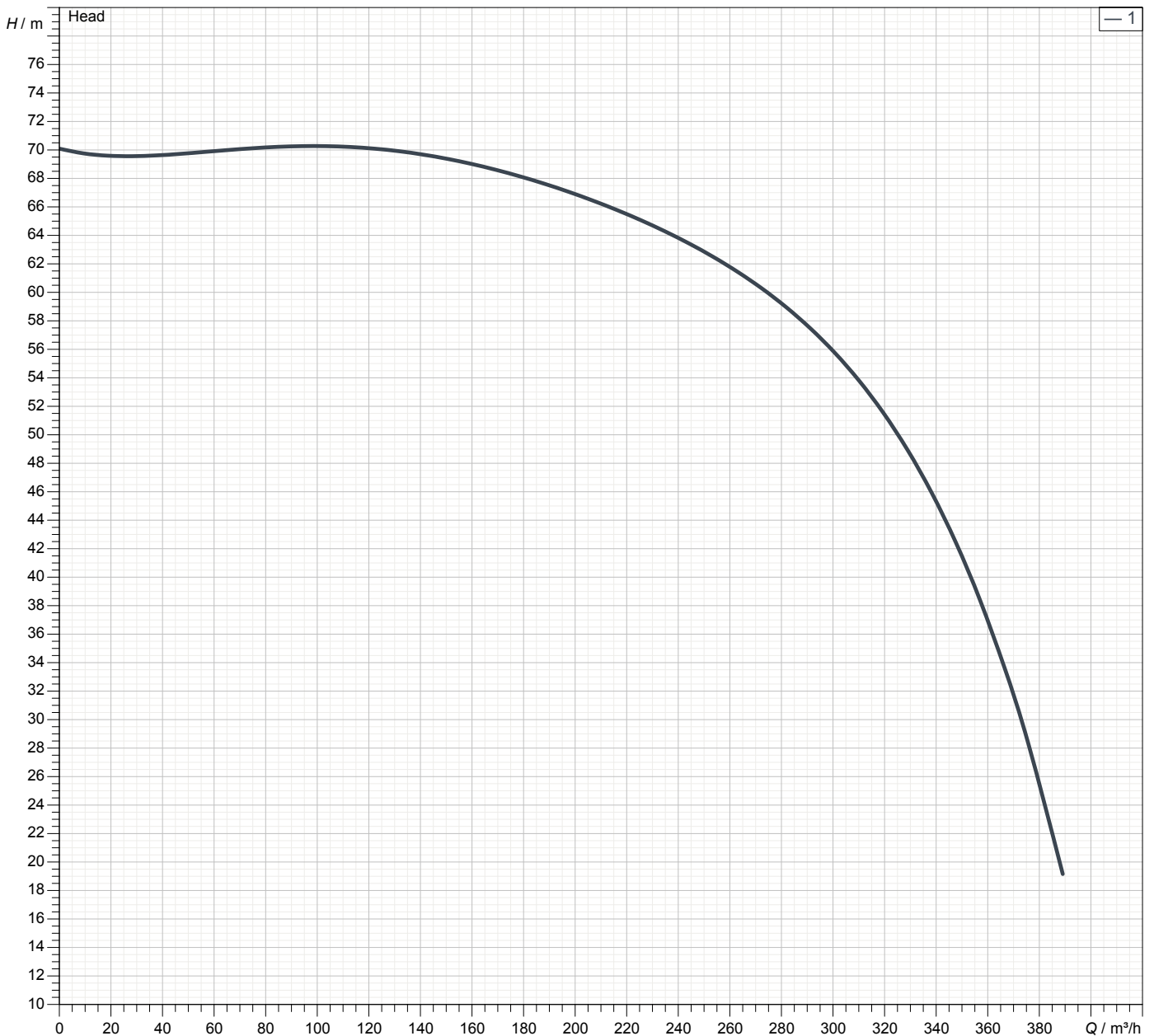

Dimensions

LH875-51

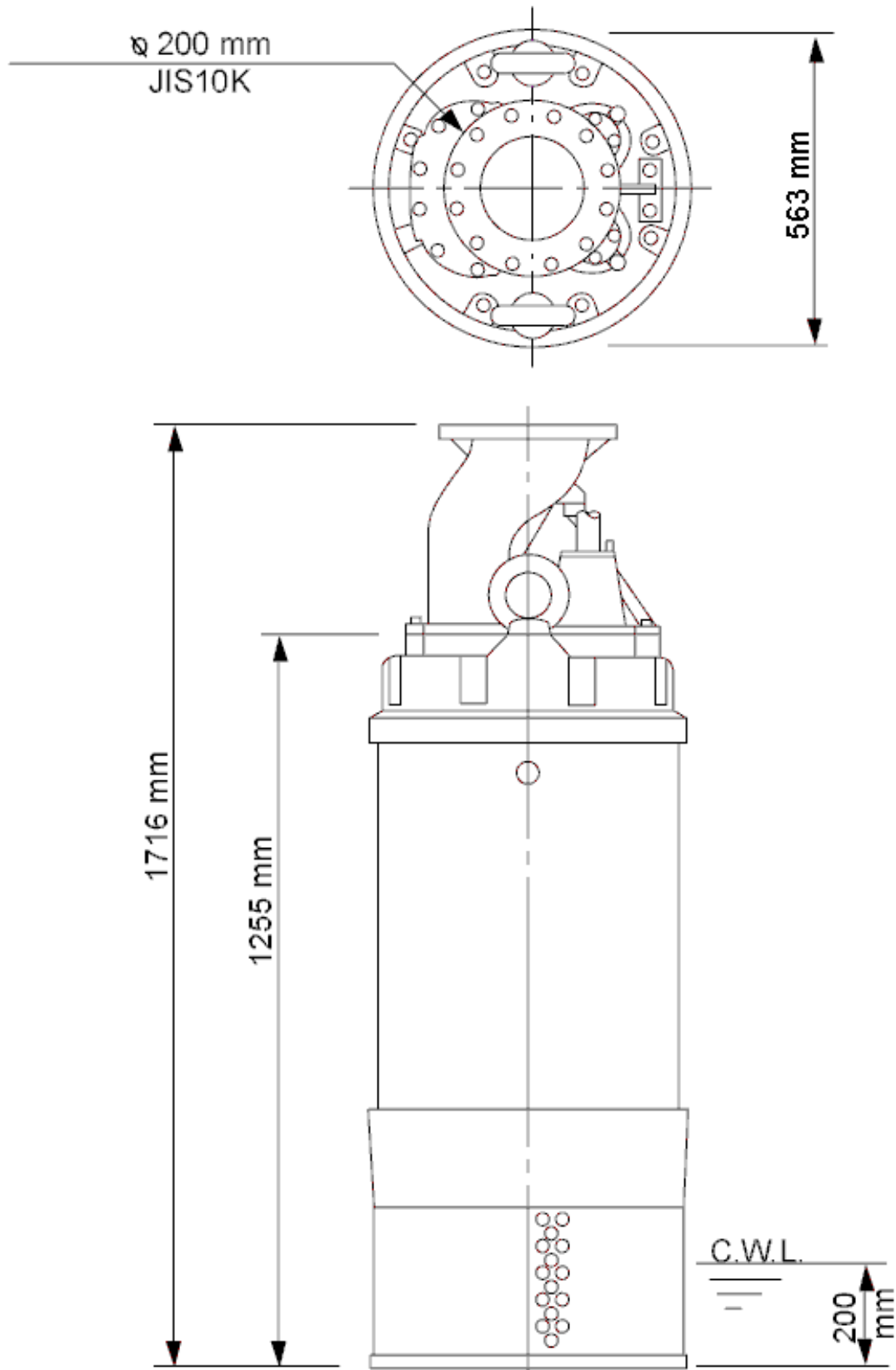

LH875-51

CWL: Continuous running water level
LWL: Lowest running water level

Sectional drawing LH875-51

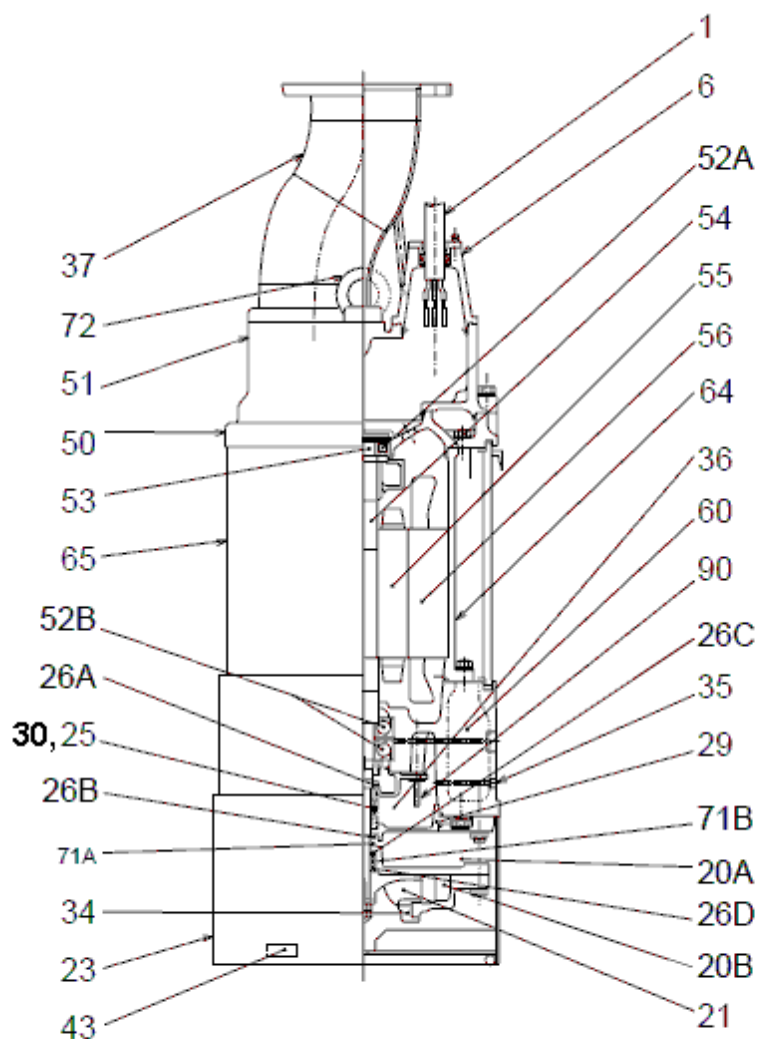

LH875-51

No.	Description	Remark	No.	Description	Remark
1	Cable	20m NSSHÖU	37	Discharge coupling	Baustahl / Stahlrohr
6	Stuffing box	FC200 (EN-GJL-200)	43	Sacrificial anode (3x)	Aluminium alloy
20A	Upper Pump casing	FC200 (EN-GJL-200)	50	Motor cover	FC200 (EN-GJL-200)
20B	Lower Pump casing	FC200 (EN-GJL-200)	51	Main cover	FC200 (EN-GJL-200)
21	Impeller	Chromium iron casting	52A	Upper bearing	NU310C3
23	Strainer	Construction steel SS400	52B	Lower bearing	7313BTDBC3
25	Mechanical seal	H-50TX	53	Miniature protector (3x)	.
26A	Oil seal	TC60759	54	Shaft	SUS420J2 (EN-X30Cr13)
26B	Oil seal	TC557812	55	Rotor	.
26C	Oil seal	TCN557812	56	Stator	.
26D	Labyrinth ring only	SUS304 (EN-X5CrNi18-10)	60	Bearing Housing	FC200 (EN-GJL-200)
29	Oil casing	FC200 (EN-GJL-200)	64	Motor Frame	FC200 (EN-GJL-200)
30	Oil distributor	Plastic	65	Outer Cover	Carbon steel
34	Wear Ring	Chromium iron casting	71A	Upper shaft protection sleeve	SUS403 (EN-X6Cr13)
35	Oil screw (2x)	SUS304 (EN-X5CrNi18-10)	71B	Lower shaft protection sleeve	SUS403 (EN-X6Cr13)
36	Lubricant	Turbine oil (ISO VG32)	72	Eye screw	Construction steel SS400