

# Data sheet LH645-50

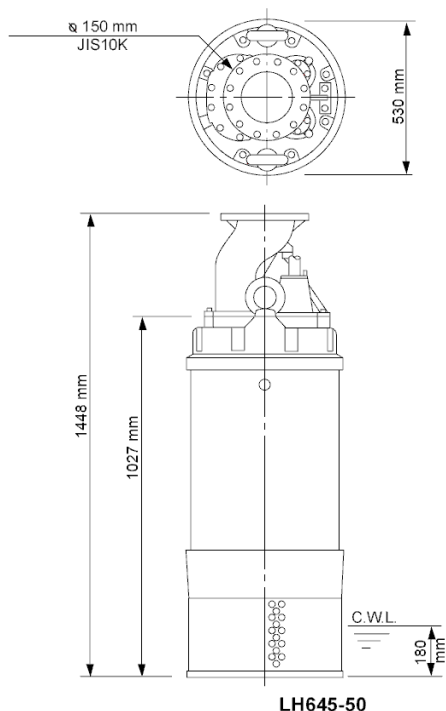

## Specification

Electric submersible pump LH-series  
 Degree of protection IP 68  
 Pressure resistance max. 30 m  
 Type of impeller Closed  
 Max. solid handling 6 mm  
 Suitable for:  
 rain water, ground water, sand water

## Electric motor

Dry-type submersible induction motor  
 Insulation class F 2Poles 2940 1/min  
 Starting mode Star-delta  
 Rated voltage 400 V 50 Hz 3~  
 Power uptake 50,68 kW  
 Rated power 45,00 kW  
 Rated current 81 A  
 Start current 600,2 A

## Cable

20m NSSHÖU 7Cx35mm² + 3x2,5mm²ST

## Motor Protection

Miniature protector in windings  
 (snap-action bi-metal device)

## Shaft seal

Double inside mechanical seal in oil bath  
 additional lubrication by oil lifting device  
 Primary seal  
 Silicon carbide on silicon carbide  
 Secondary seal  
 Silicon carbide on carbon

## Bearings

Shielded ball bearings, maintenance-free

## Materials

Impeller	Chromium iron casting
Pump casing	FC200 (EN-GJL-200)
Wear Ring	FC200 (EN-GJL-200)
Wear Ring	Chromium iron casting
Motor Frame	FC200 (EN-GJL-200)
Shaft	SUS420J2 (EN-X30Cr13)

## Discharge size

150mm JIS10K flange

## Weight

510 kg (dry weight of the pump only without cable)

# Performance curve

## LH645-50

Discharge port	6"
Head	90,2 m
Flow	178,4 m³/h
Rated power	45,00 kW
Power input	50,68 kW
Phases	3~
Voltages	400 V
Frequency	50 Hz
Rated current	81 A
Starting current	200,07 A
Number of poles	2
Speed	2940 1/min
Starting mode	Star-delta
Insulation class	F

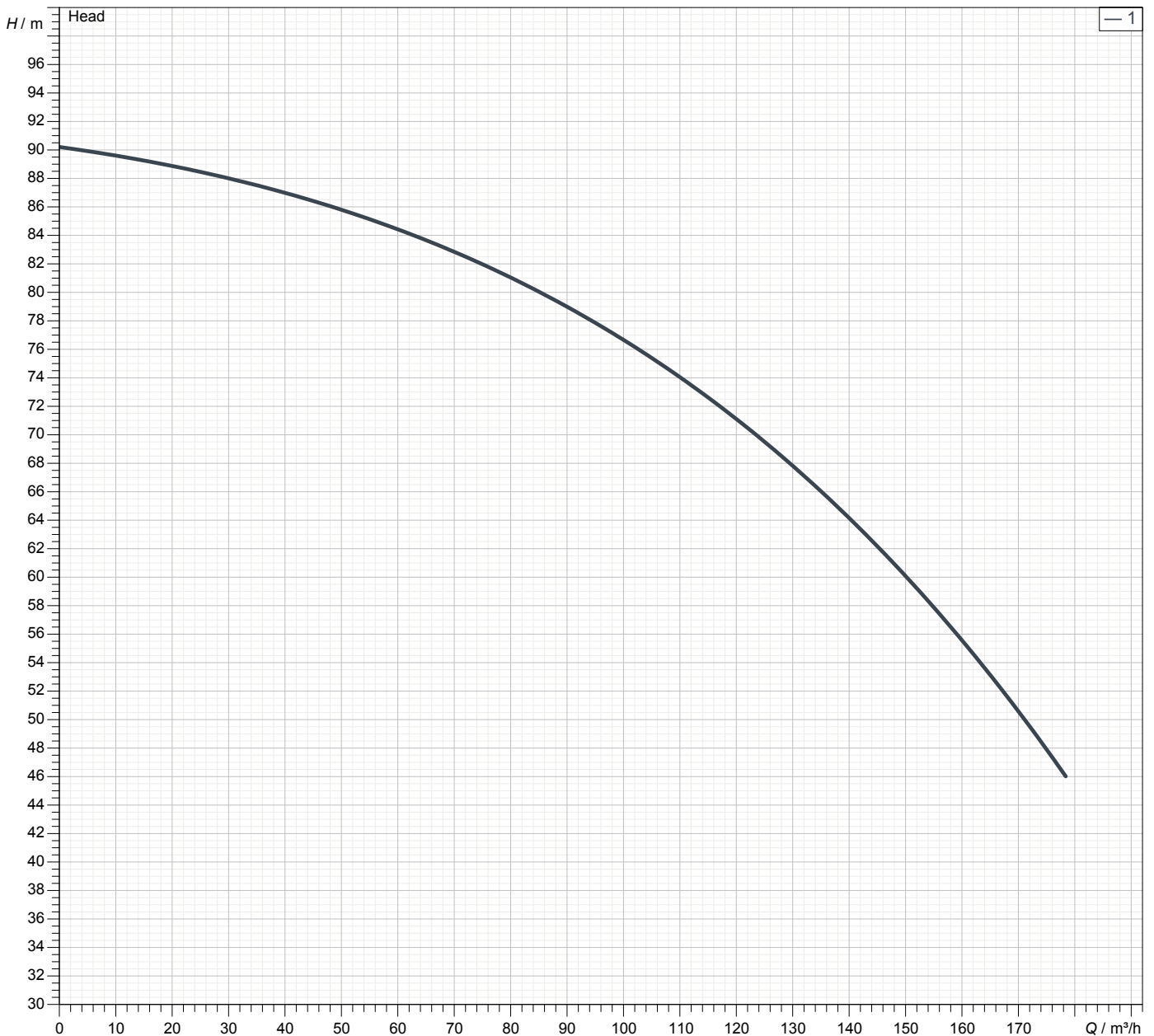

# Dimensions

## LH645-50

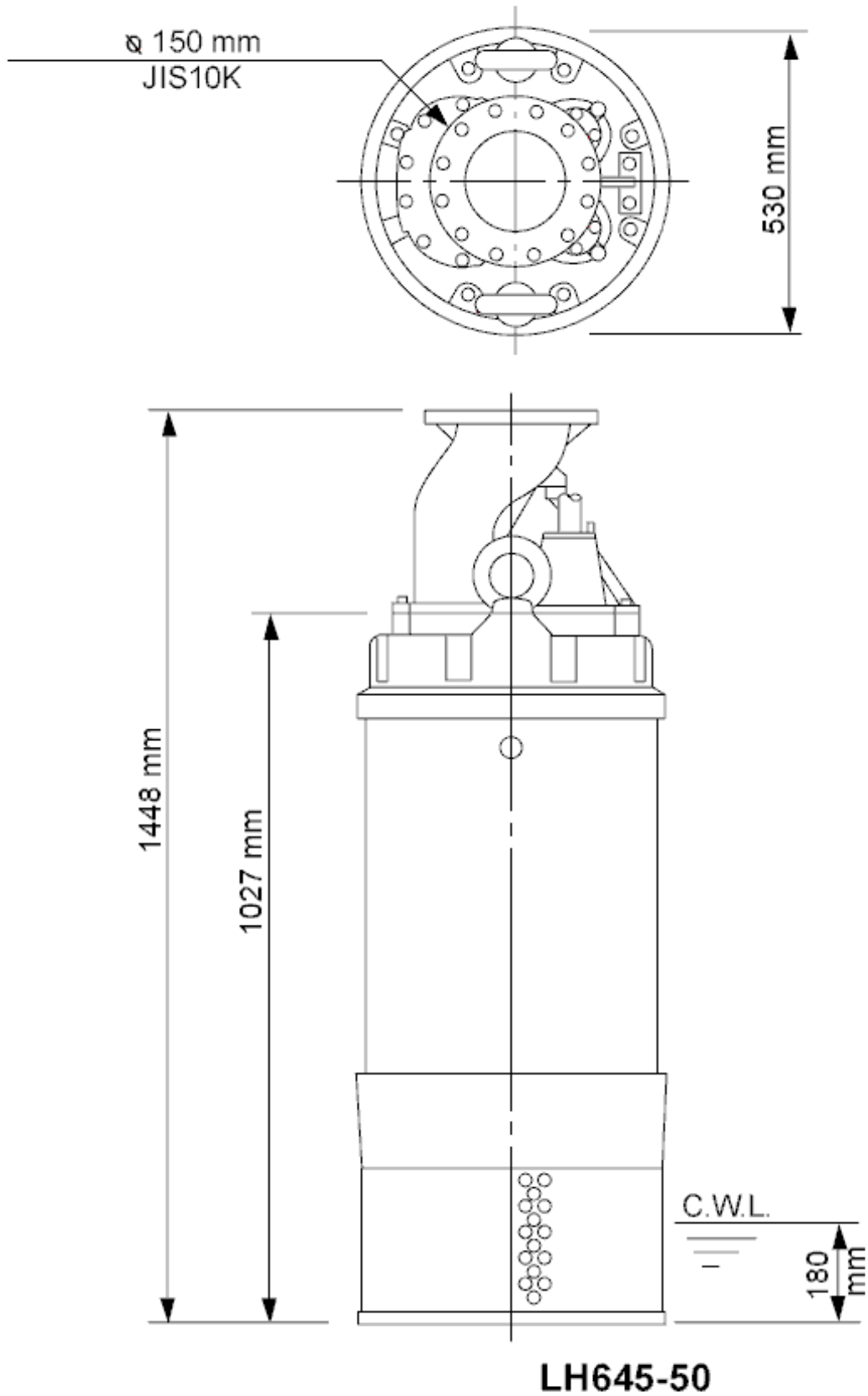

CWL: Continuous running water level  
LWL: Lowest running water level

# Sectional drawing LH645-50

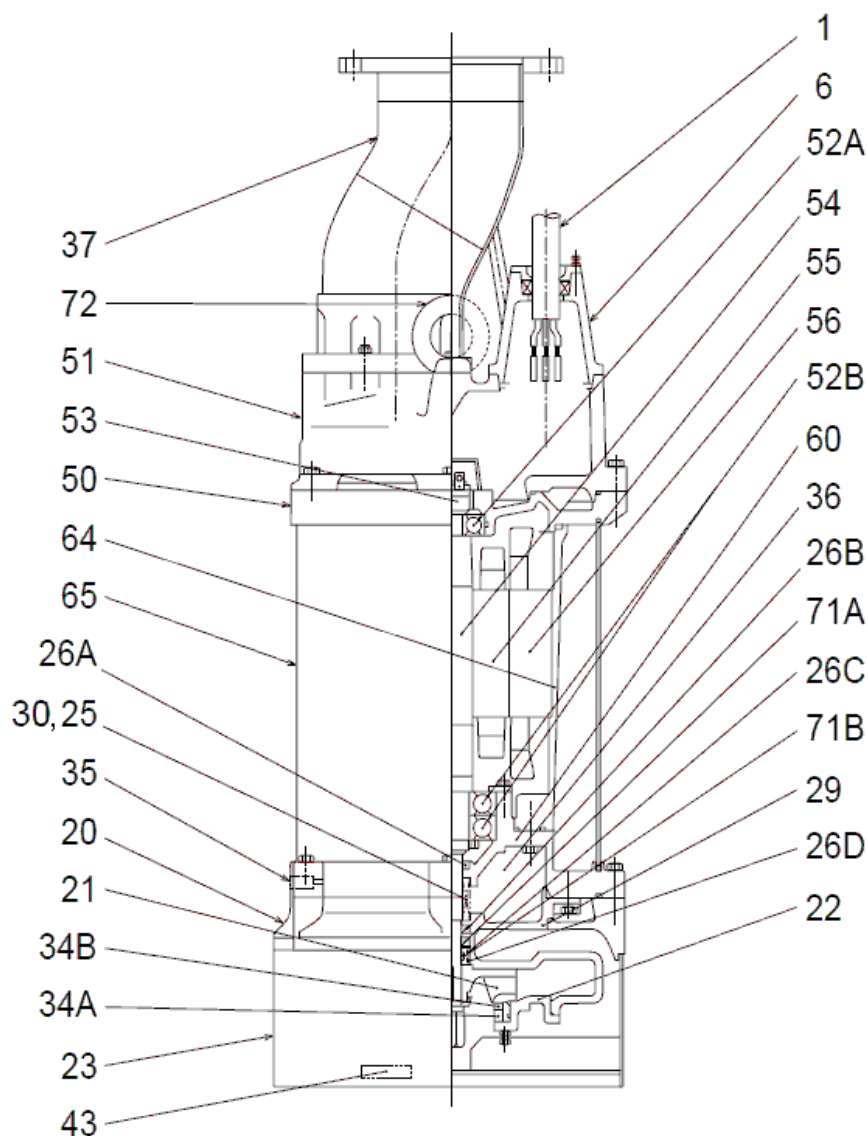

**LH645-50**

No.	Description	Remark	No.	Description	Remark
1	Cable	20m NSSHÖU	36	Lubricant	Turbine oil (ISO VG32)
6	Stuffing box	FC200 (EN-GJL-200)	37	Discharge coupling	Baustahl / Stahlrohr
20	Pump casing	FC200 (EN-GJL-200)	43	Sacrificial anode (3x)	Aluminium alloy
21	Impeller	Chromium iron casting	50	Motor cover	FC200 (EN-GJL-200)
22	Suction cover	FC200 (EN-GJL-200)	51	Main cover	FC200 (EN-GJL-200)
23	Strainer	Construction steel SS400	52A	Upper bearing	6307ZZC3
25	Mechanical seal	HT-3540	52B	Lower bearing	6311ZZD2C3
26A	Oil seal	SC40588	53	Miniature protector (3x)	.
26B	Oil seal	TC385811	54	Shaft	SUS420J2 (EN-X30Cr13)
26C	Oil seal	TCN385811	55	Rotor	.
26D	Labyrinth ring only	SUS304 (EN-X5CrNi18-10)	56	Stator	.
29	Oil casing	FC200 (EN-GJL-200)	60	Bearing Housing	FC200 (EN-GJL-200)
30	Oil distributor	Plastic	64	Motor Frame	FC200 (EN-GJL-200)
34A	Wear Ring	FC200 (EN-GJL-200)	65	Outer Cover	Construction steel SS400
34B	Wear Ring	Chromium iron casting	71A	Upper shaft protection sleeve	SUS403 (EN-X6Cr13)
35	Oil screw (2x)	SUS304 (EN-X5CrNi18-10)	71B	Lower shaft protection sleeve	SUS403 (EN-X6Cr13)