

Data sheet LH637-50

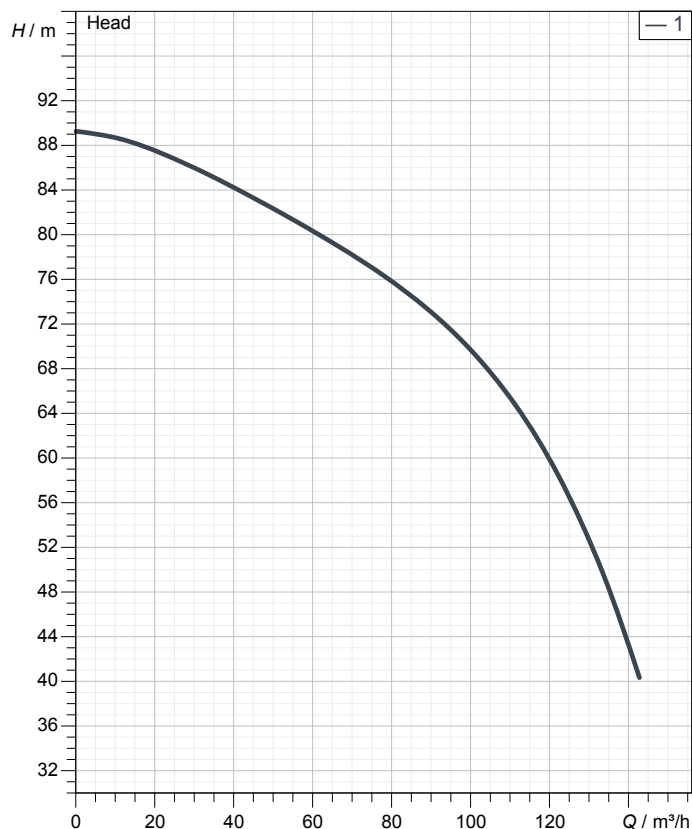
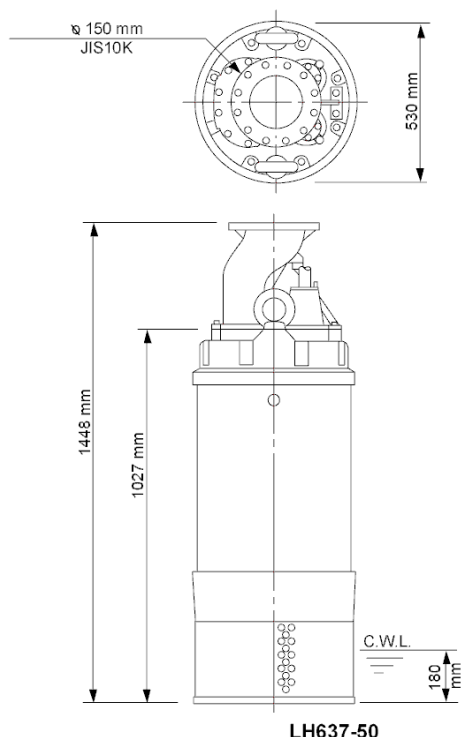

Specification

Electric submersible pump LH-series
 Degree of protection IP 68
 Pressure resistance max. 30 m
 Type of impeller Closed
 Max. solid handling 6 mm
 Suitable for:
 rain water, ground water, sand water

Electric motor

Dry-type submersible induction motor
 Insulation class F 2Poles 2940 1/min
 Starting mode Star-delta
 Rated voltage 400 V 50 Hz 3~
 Power uptake 42,00 kW
 Rated power 37,00 kW
 Rated current 67 A
 Start current 460,3 A

Cable

20m NSSHÖU 7Cx35mm² + 3x2,5mm²ST

Motor Protection

Miniature protector in windings
 (snap-action bi-metal device)

Shaft seal

Double inside mechanical seal in oil bath
 additional lubrication by oil lifting device
 Primary seal
 Silicon carbide on silicon carbide
 Secondary seal
 Silicon carbide on carbon

Bearings

Shielded ball bearings, maintenance-free

Materials

Impeller	Chromium iron casting
Pump casing	FC200 (EN-GJL-200)
Wear Ring	FC200 (EN-GJL-200)
Wear Ring	Chromium iron casting
Motor Frame	FC200 (EN-GJL-200)
Shaft	SUS420J2 (EN-X30Cr13)

Discharge size

150mm JIS10K flange

Weight

495 kg (dry weight of the pump only without cable)

Performance curve

LH637-50

Discharge port	6"
Head	89,3 m
Flow	142,8 m³/h
Rated power	37,00 kW
Power input	42,00 kW
Phases	3~
Voltages	400 V
Frequency	50 Hz
Rated current	67 A
Starting current	153,43 A
Number of poles	2
Speed	2940 1/min
Starting mode	Star-delta
Insulation class	F



Dimensions

LH637-50

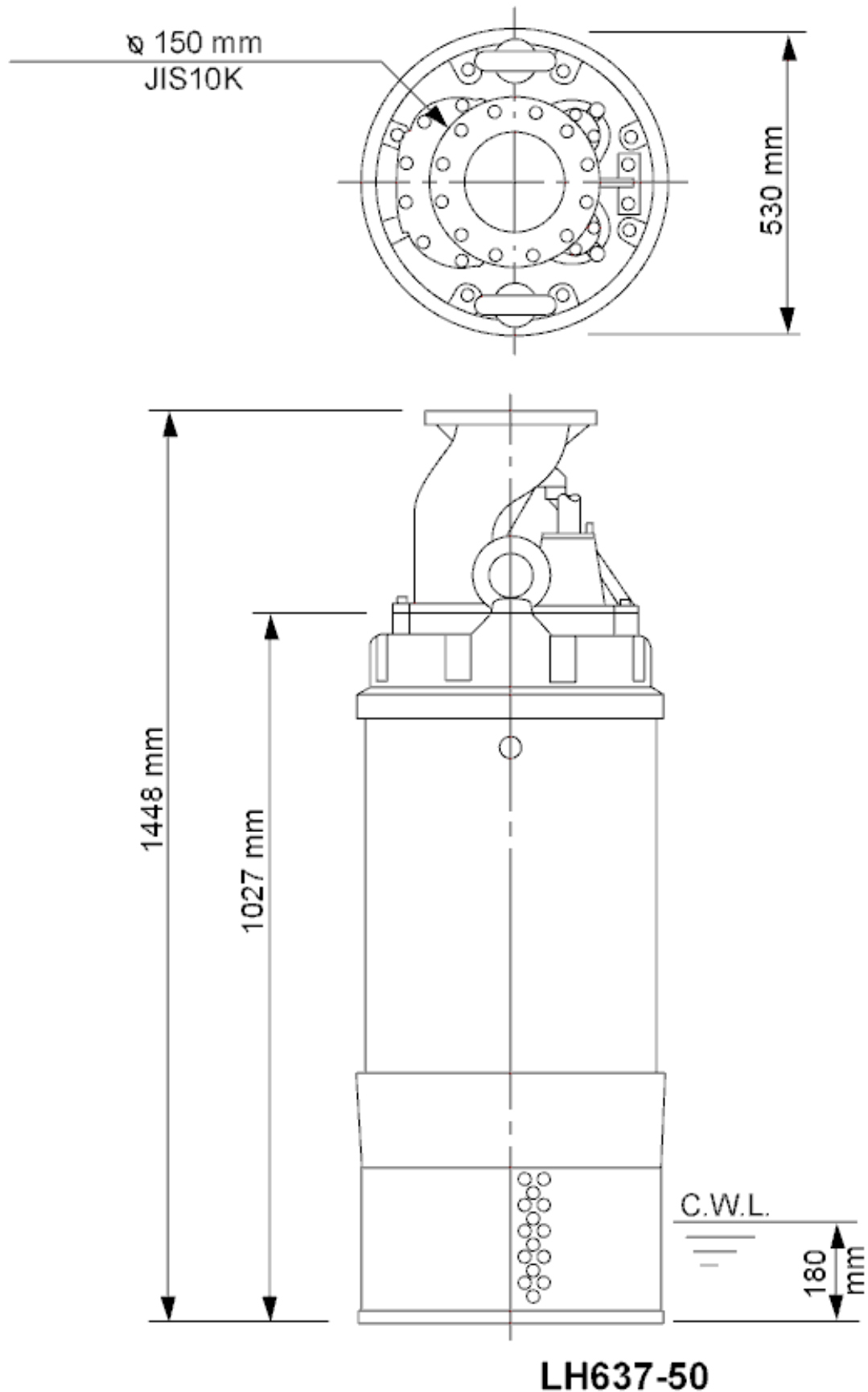

CWL: Continuous running water level
LWL: Lowest running water level

Sectional drawing LH637-50

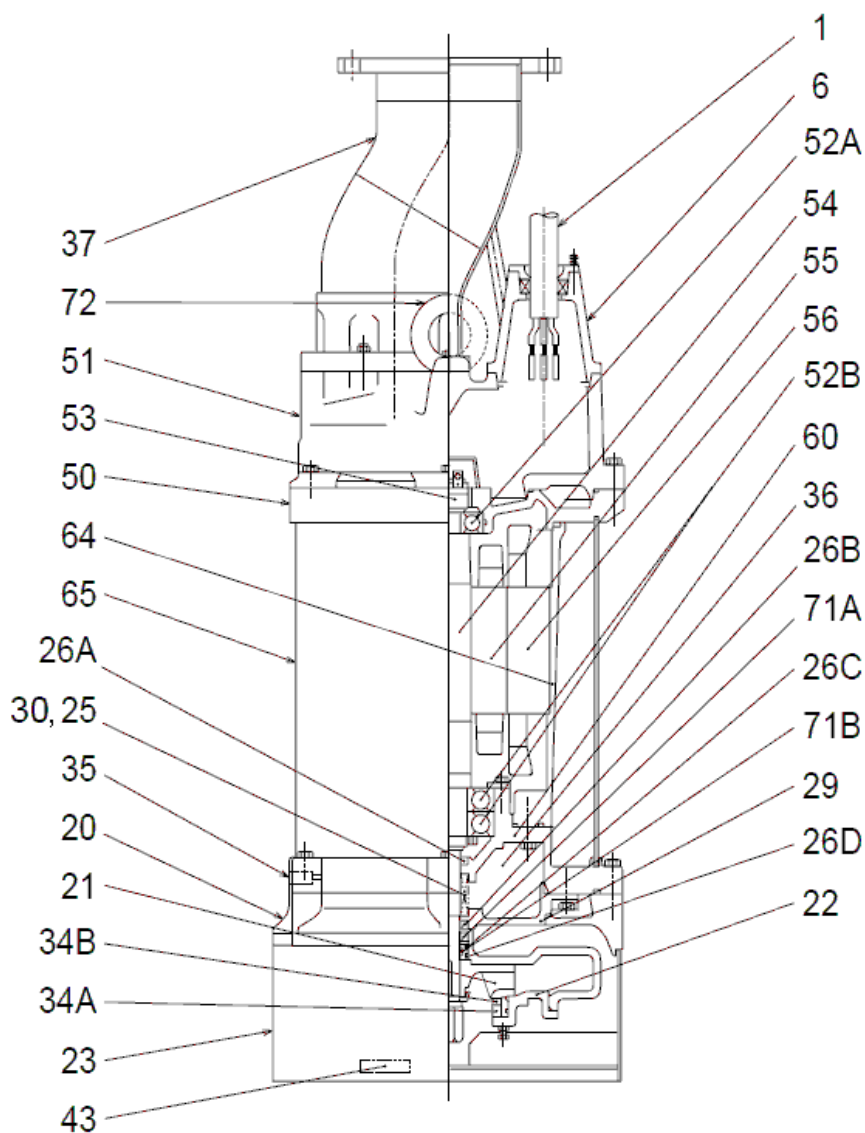

LH637-50

No.	Description	Remark	No.	Description	Remark
1	Cable	20m NSSHÖU	36	Lubricant	Turbine oil (ISO VG32)
6	Stuffing box	FC200 (EN-GJL-200)	37	Discharge coupling	Baustahl / Stahlrohr
20	Pump casing	FC200 (EN-GJL-200)	43	Sacrificial anode (3x)	Aluminium alloy
21	Impeller	Chromium iron casting	50	Motor cover	FC200 (EN-GJL-200)
22	Suction cover	FC200 (EN-GJL-200)	51	Main cover	FC200 (EN-GJL-200)
23	Strainer	Construction steel SS400	52A	Upper bearing	6307ZZC3
25	Mechanical seal	HT-4550N	52B	Lower bearing	6311ZZD2C3
26A	Oil seal	SC40588	53	Miniature protector (3x)	.
26B	Oil seal	TC385811	54	Shaft	SUS420J2 (EN-X30Cr13)
26C	Oil seal	TCN385811	55	Rotor	.
26D	Labyrinth ring only	SUS304 (EN-X5CrNi18-10)	56	Stator	.
29	Oil casing	FC200 (EN-GJL-200)	60	Bearing Housing	FC200 (EN-GJL-200)
30	Oil distributor	Plastic	64	Motor Frame	FC200 (EN-GJL-200)
34A	Wear Ring	FC200 (EN-GJL-200)	65	Outer Cover	Construction steel SS400
34B	Wear Ring	Chromium iron casting	71A	Upper shaft protection sleeve	SUS403 (EN-X6Cr13)
35	Oil screw (2x)	SUS304 (EN-X5CrNi18-10)	71B	Lower shaft protection sleeve	SUS403 (EN-X6Cr13)