

# Data sheet KTZ611-53

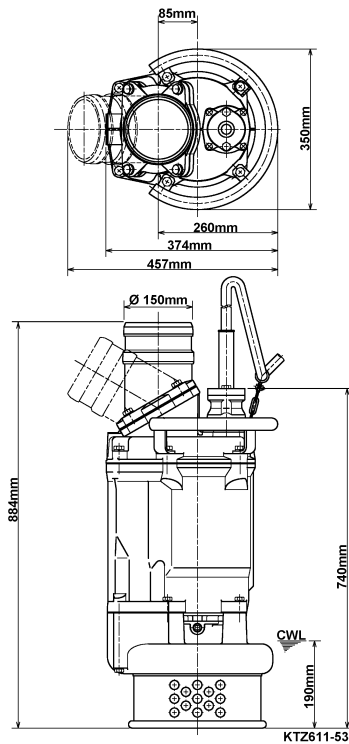

CWL: Continuous running water level

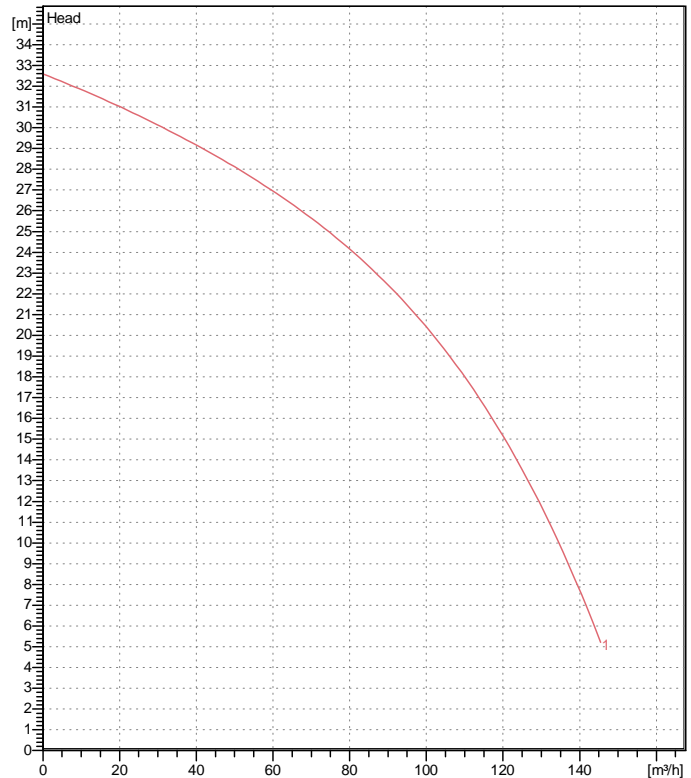

## Specification

Electric submersible pump  
 Degree of protection IP 68  
 Depth of submersion max. 25 m  
 Type of impeller Semi-open  
 Max. solid handling 20 mm  
 Suitable for:  
 spring-/rain-/waste-/ground water, water containing sand

## Electric motor

Dry-type submersible induction motor  
 Insulation class F 2Poles 2935 1/min  
 Starting mode Directly  
 Rated voltage 400 V 50 Hz 3~  
 Power uptake 13,80 kW  
 Rated power 11,00 kW  
 Rated current 22 A  
 Start current 152,9 A

## Cable

20m NSSHÖU 4Cx4mm<sup>2</sup>

## Motor Protection

Circle thermal protector  
 (snap-action bi-metal device)

## Shaft seal

Double inside mechanical seal in oil bath  
 additional lubrication by oil lifting device

Primary seal  
 Silicon carbide on silicon carbide  
 Secondary seal  
 Silicon carbide on carbon

## Bearings

Shielded ball bearings, maintenance-free

## Materials

Impeller	Chromium Iron HiCrFC
Pump casing	FC200 (EN-GJL-200)
Suction cover	FCD50 (EN-GJS-500-7)
Motor Frame	FC150 (EN-GJL-150)
Shaft	SUS420J2 (EN-X30Cr13)

## Discharge size

6" (150mm) BS-coupling (threaded flange)

## Weight

131 kg (dry weight of the pump only without cable)

# Performance curve

## KTZ611-53

Discharge port	6"
Head	32,6 m
Flow	145,5 m <sup>3</sup> /h
Rated power	11,00 kW
Power input	13,80 kW
Phases	3~
Voltages	400 V
Frequency	50 Hz
Rated current	22 A
Starting current	152,90 A
Number of poles	2
Speed	2935 1/min
Starting mode	Directly
Insulation class	F

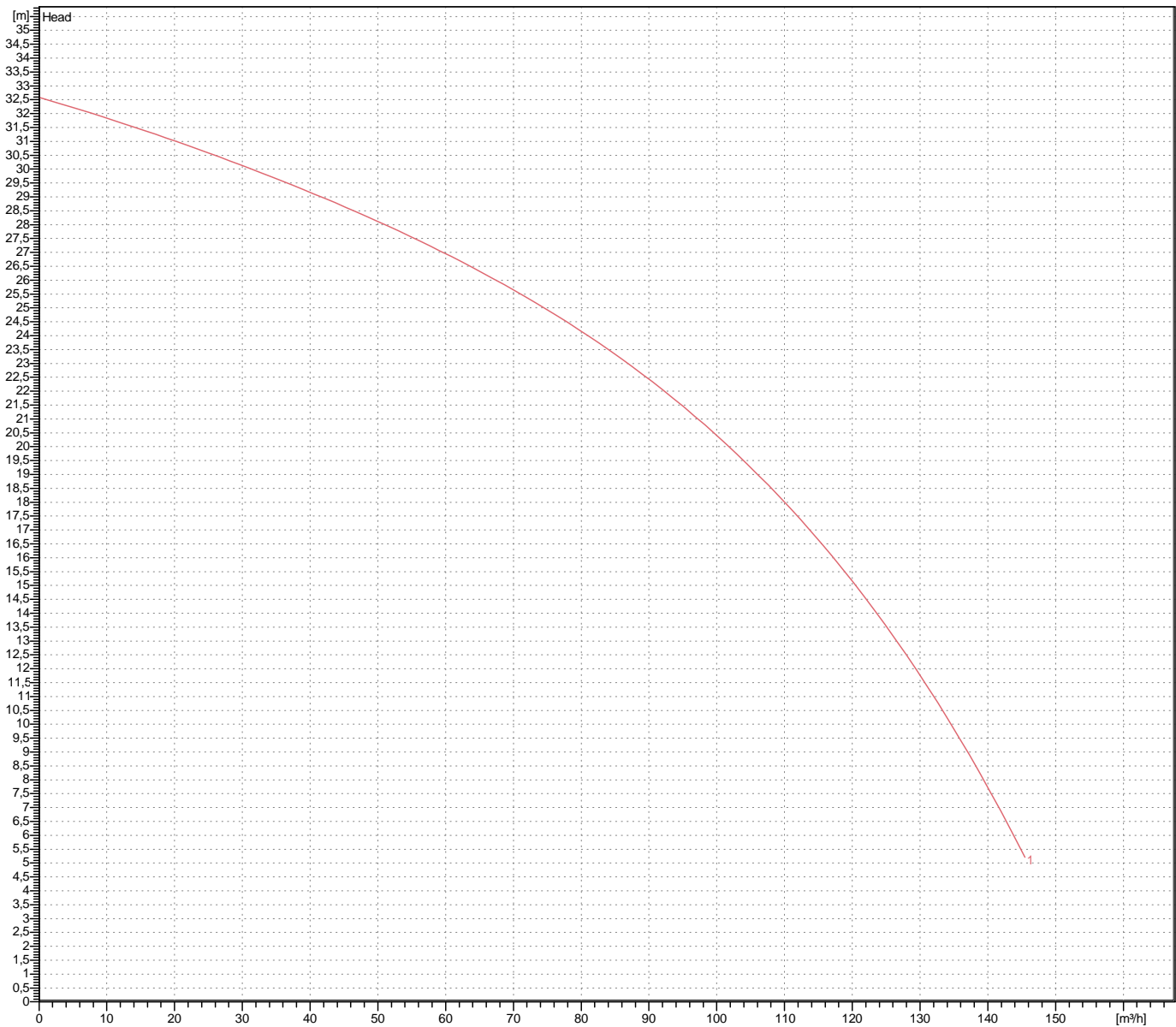

# Dimensions KTZ611-53

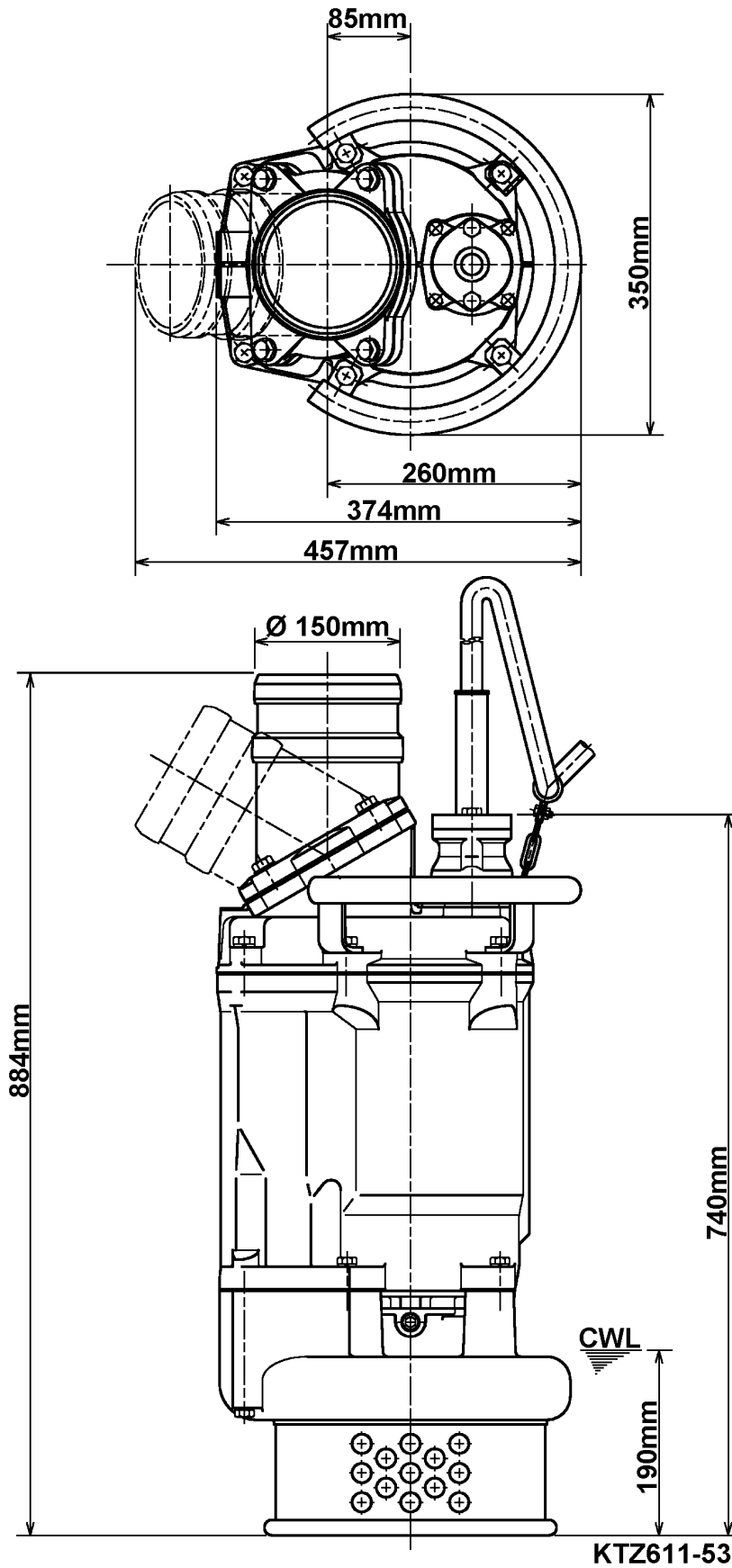

CWL: Continuous running water level  
LWL: Lowest running water level

# Sectional drawing KTZ611-53

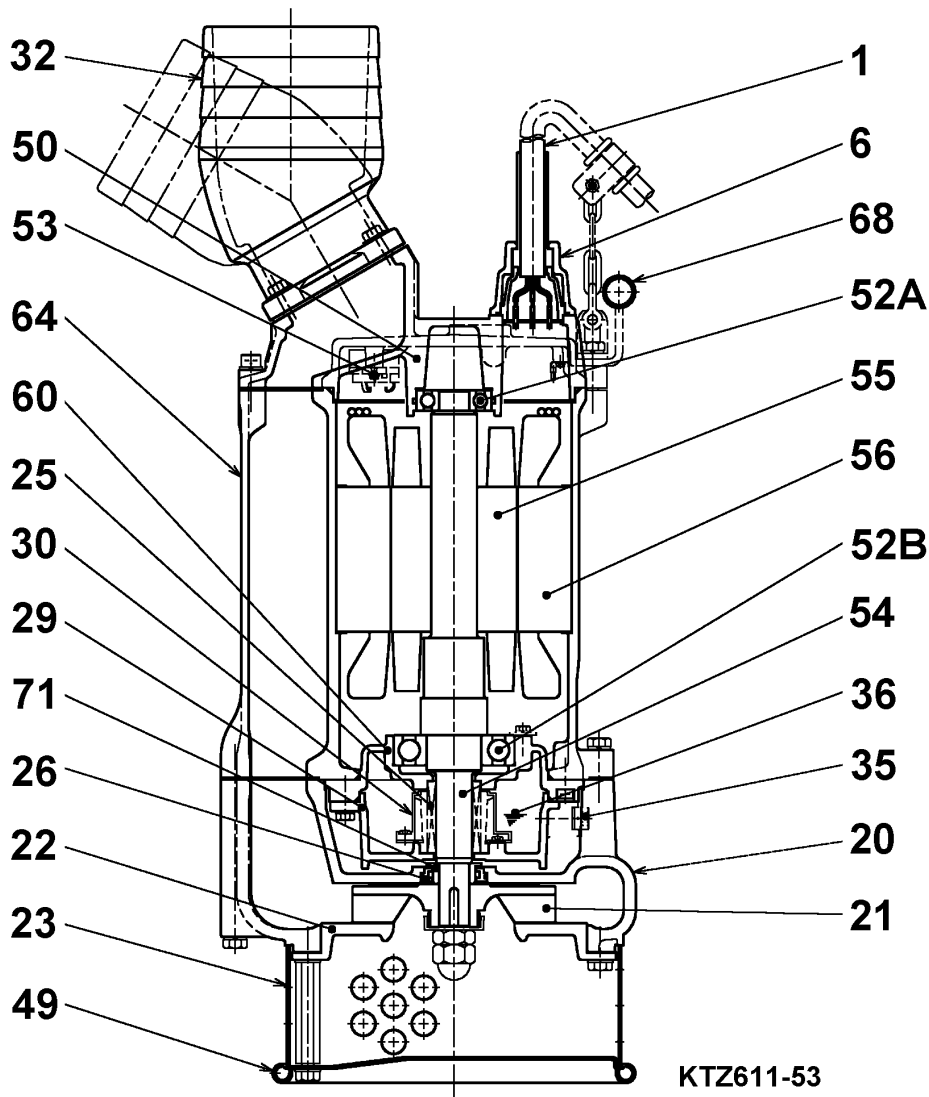

KTZ611-53

No.	Description	Remark	No.	Description	Remark
1	Cable	20m NSSHÖU	52B	Lower bearing	6309ZZC3
6	Stuffing box	FC200 (EN-GJL-200)	53	Motor Protector 380/400/415V	50Hz KA314-HRXL00 (H.C)
20	Pump casing	FC200 (EN-GJL-200)	54	Shaft	SUS420J2 (EN-X30Cr13)
21	Impeller	Chromium Iron HiCrFC	55	Rotor	.
22	Suction cover	FCD50 (EN-GJS-500-7)	56	Stator	.
23	Strainer	Steel plate	60	Bearing Housing	FC150 (EN-GJL-150)
25	Mechanical seal	HT-3035N	64	Motor Frame	FC150 (EN-GJL-150)
26	Labyrinth ring only	SUS304 (EN-X5CrNi18-10)	68	Handle	steel pipe / Sectional steel
29	Oil casing	FC200 (EN-GJL-200)	71	Shaft protection sleeve	SUS403 (EN-X6Cr13)
30	Oil distributor	Plastic			
32	Discharge coupling	FC200 (EN-GJL-200)			
35	Oil screw	SUS304 (EN-X5CrNi18-10)			
36	Lubricant	Turbine oil (ISO VG32)			
49	Bottom Plate	Steel plate SPCC			
50	Main cover	FC150 (EN-GJL-150)			
52A	Upper bearing	6306ZZC3			